

PRODUCT OVERVIEW



Designed specifically for high-quality linear LED lighting installations, our **24V CS35120CCT** LED strip allows you to create long lasting, headache-free lighting right out of the package. Easily cut, peel, and stick the flexible light tape to your mounting surface using the durable and permanent 3M® adhesive backing. Achieve well over **50,000 hours** of useful lighting when used with one of our aluminum profiles for LED strips to draw out the heat and protect the strips from damaging elements. Our **24V CS35120CCT** LED Tape comes with the UL-stamp of approval and is **UL-listed** for use in both the United States and Canada (cUL).

The **24V CS35120CCT** LED Strip comes in a **16'5" roll/reel** and is **0.39" (10mm) wide**. **3528** LED chips are mounted on a flexible PCB every **0.31"** apart. The full LED strip spool has about 600LED chips packed in **high-density—36 LED/ft (120/M)**—configuration. The LED strip comes with **(1) 6" 18-3 wire lead** with bare, tin-coated ends, for fast and reliable wire-to-wire connections. This LED Strip consumes an average of **5 Watts/ft**. Effortlessly cut this LED strip every **2"** (or every 6 LED chips).

Strip Specifications	
Part#	24VCS35120CCT*
Roll Length	16'5" (197")
Input Voltage	24VDC
Strip Width	0.39" (10mm)
Cut Increments	Cuttable every 2"
Color Rendering	>90
LED Type	3528
LED Density	36 LED's per foot (120/M)
Wattage	5 Watts/ft
Light Output	440 Lumens/ft (Average)
Efficiency	88 Lumens/Watt
Lifetime	50,000 Hours (Average)
Warranty	3-Year Limited Warranty
IP-Rating	IP-23 (Suitable for Indoor Use)
Listings	UL-Listed (US and Canada)

Available Colors



Tunable White
CCT 2700K - 6000K

Cut Points

Cut Every 2"



0.48" (12mm)

Packaging



6" Pre-Soldered Lead

Features

- Select from our **wide variety** of control options to achieve a CCT ranging from **2600K-7000K**.
- **High-Quality LED Strip!** Excellent thermal management for lasting installations.
- **UL-Listed!** (in US and Canada) Specify our strips on any commercial project!
- Easy mounting using VHB **double-sided tape**.

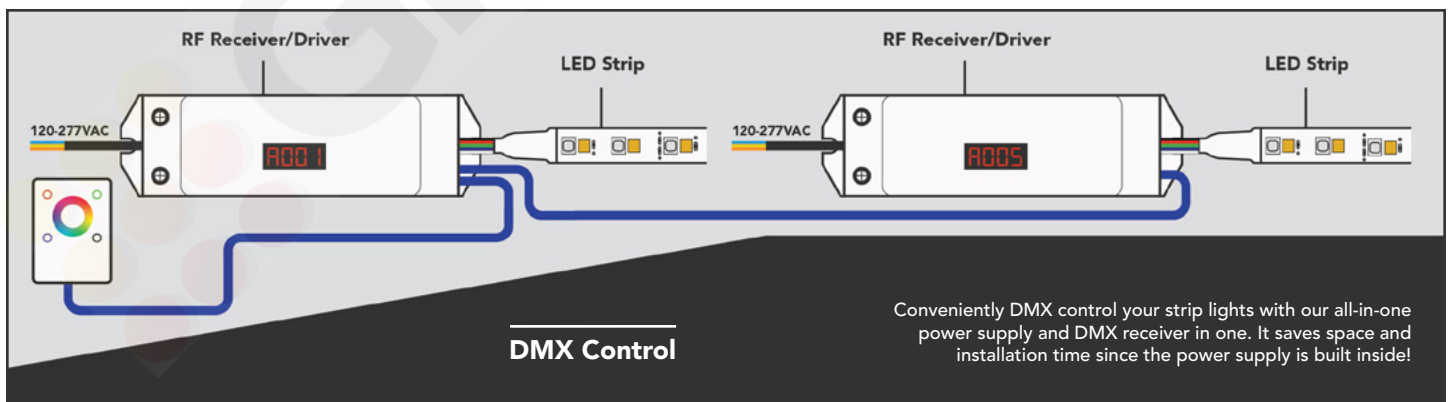
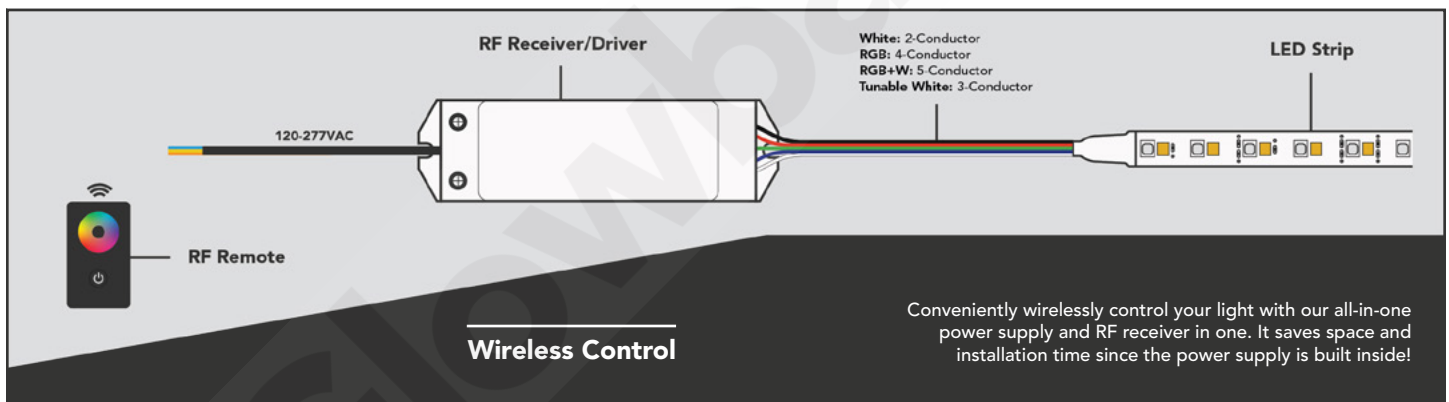
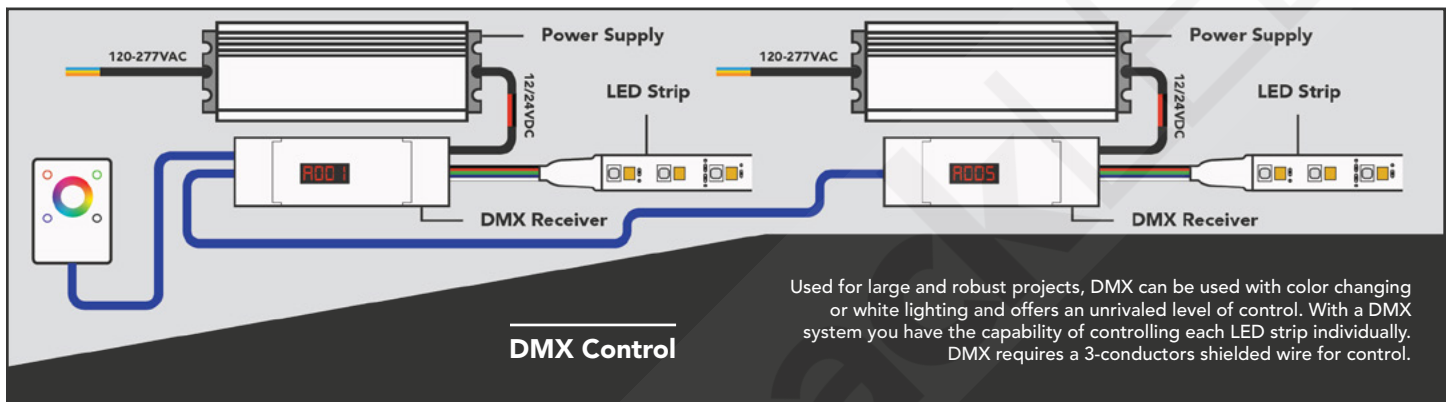
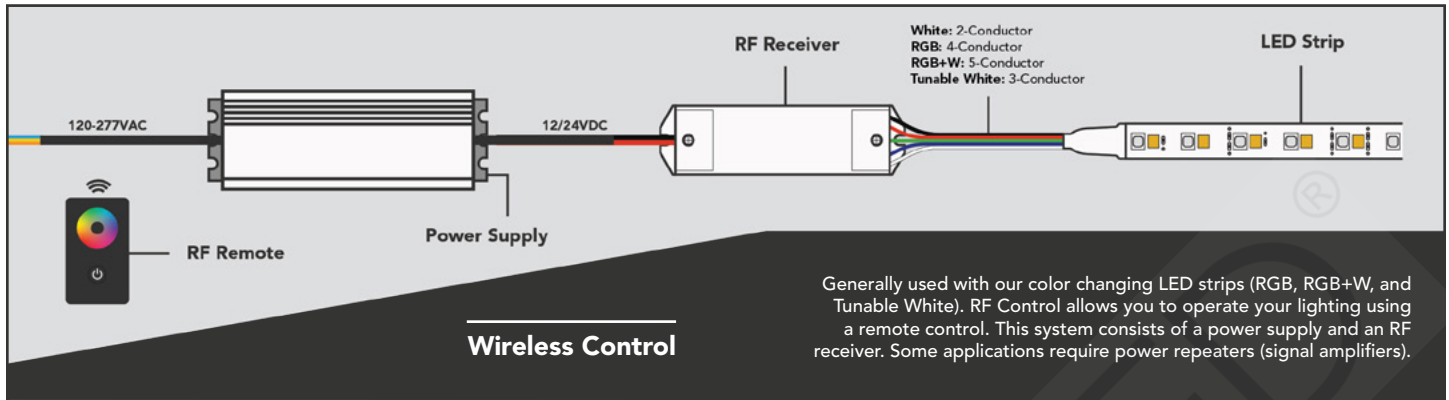

All of our LED Panels require a remote power supply and/or controller to operate. Seamlessly integrate our LED Panel systems with any type of home or building automation system. Unless otherwise specified, all LED Panel systems, including power supplies and controllers are shipped to you pre-configured, to facilitate installation. Power-Supplies will come "rigged" with connectors to match the connectors coming off the LED panels. When ordering, simply give us some details about the level of control that you want, and our team will design a turn-key control system fit to meet your needs.